

The overall dimensions 671mm and 219mm are not allowed to be higher. The upstand is not allowed to be more than 14mm.

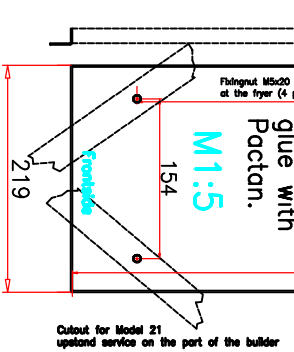

Cutout for Model 21 upstand service on the part of the builder

Please take care by installation of the fryer unit to give enough space for ventilation and heat flow below the fryer unit. It is required that there are at least openings of 100 cm². The temperature in the sub-structure (below the unit) is not allowed to exceed 60 ° C.

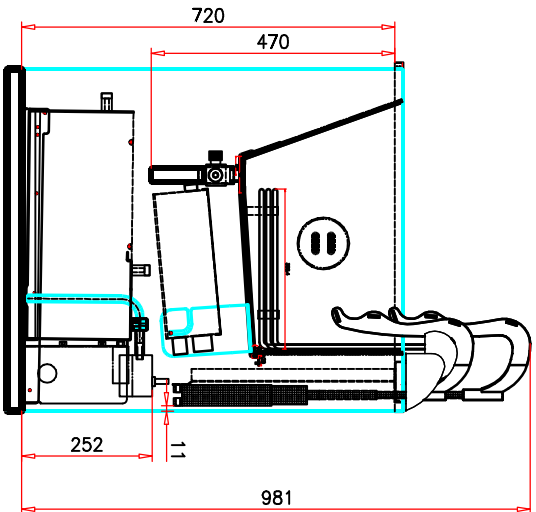

Type: VXE21P
Control type Primus
Tank
Length
Version: built-in
Series

Options:
F = Filter and pump system
L1 = Lift

Technical Data	
Heater Power	7.5kW 5 W/cm ²
Voltage	400V 50Hz 3NAC
Fuse	3 x 16A
Mains connection	3L+N+PE L=1.5m(1cable)
Weight	1x1.25 kg
Capacity (max.)	1x1.0 kg
" (recommended)	17-22kg frozen chips
Capacity/hour	20-25kg pre-cooked chips
Oil Capacity	7-9 liter

built-in fryer VXE 21 P
Model VXE 21 P

Kienle GmbH Fritter-Technologie
D-72469 Messstetten-Hornheim
Telefon 07579 920-0
Telefax 07579 920-20

KIENLE

Das Urheberrecht an diesen Zeichnungen und allen Belegungen, die dem Empfänger gesetzlich zugehört sind, verbleibt jederzeit unserer Firma. Ohne unsere schriftliche Genehmigung dürfen sie nicht kopiert oder vervielfältigt, auch niemand dritten Personen mitgeteilt oder zugänglich gemacht werden.

Messstab:	Version	
1:10	Gezeichnet	12.07.2011
Blatt-Nr.:	ADM	
1		cod
Format:	Zeichnung-Nr.:	Version
A3	205719	1

Technical subject to alteration!
Version 30.06.2020