

PLACA DE INDUCCION DOBLE - PID 30



MADE IN FRANCE



Placa de cocción de doble inducción compacta y robusta

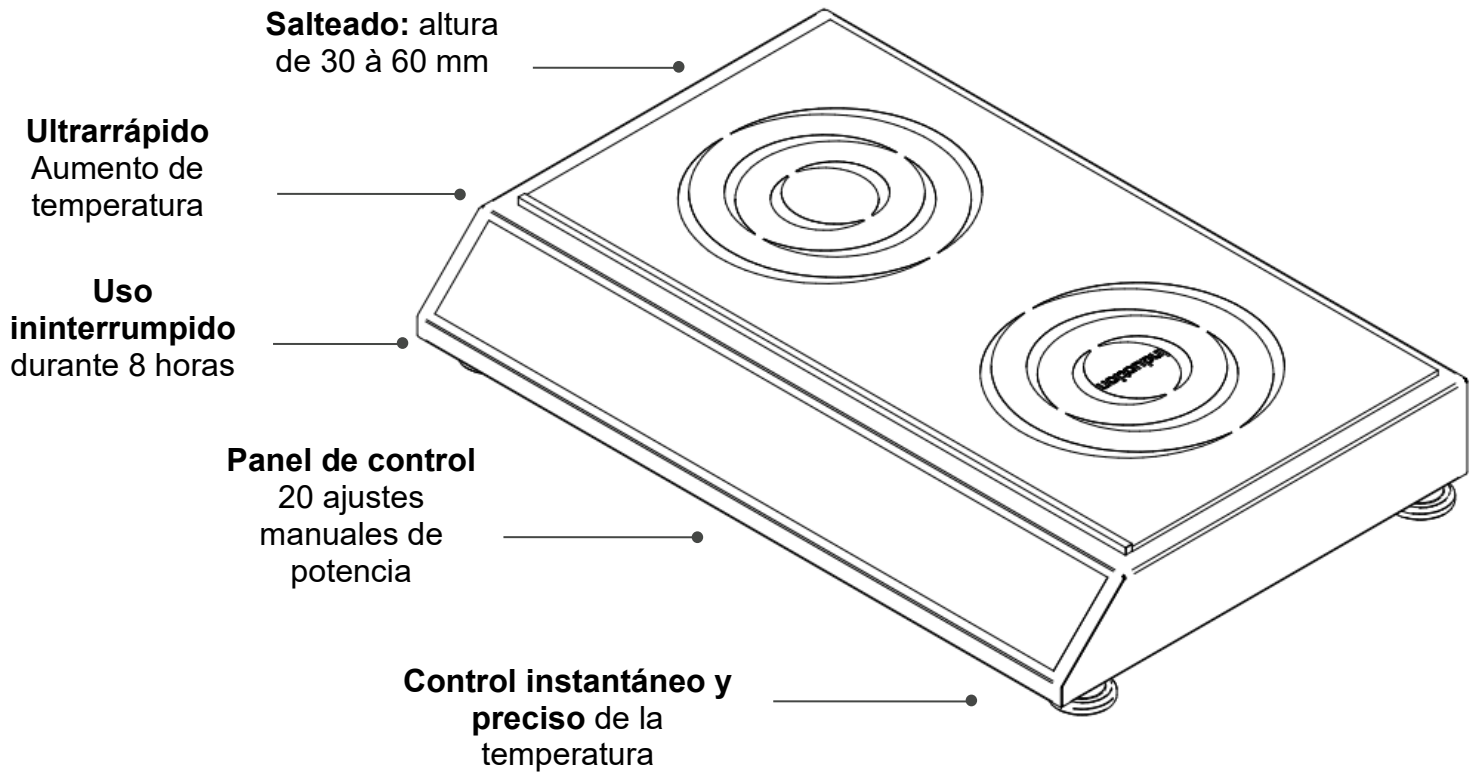

Especificaciones técnicas

Referencia	PID 30
Dimensions	380 x 590 x 102 mm
Dimensiones del vidrio	555 x 280 x 4 mm
Peso	11 Kg
Potencia	2 x 3 KW
Voltaje	2 cords 230-240 V

Descripción

- Control instantáneo y preciso de la temperatura
- Aumento de temperatura ultrarrápido
- Amplia superficie de cocción 280 x 280 mm
- Posibilidad de saltear a una altura de 30 a 60 mm según la calidad de la cazuela
- Eficiencia > 95%

Setting	1	2	3	4	5	6	7	8	9	10	11	12	13	14	15	16	17	18	19	20
Power(W) / induction box	50	100	150	200	300	400	500	600	700	800	1000	1200	1400	1600	1800	2000	2200	2400	2700	3000

